

Advantages of Word and Diagram in Describing Configuration Representation of a Mechanical System: Evidence from Eye Movements and Comprehension Tests

Yu-Cin Jian¹

Chao-Jung Wu²

¹Graduate Institute of Learning and Instruction, National Central University, Taiwan

²Department of Educational Psychology and Counseling, National Taiwan Normal University, Taiwan

E-mail: jianyucin@gmail.com

Introduction

- Previous studies have showed that advantages of word and diagram are convey kinematics and configuration relations within a mechanical system, respectively. However, in many scientific reading articles, both media describe configuration of a mechanical system jointly.
- The purpose of this study was to whether adult readers are able to form internal representations of a mechanical configuration described by a written text.

Method

Participant

- Sixty-three undergraduate or graduate participants came from universities in Taiwan volunteered to participate for a monetary reward.
- They majored in education, management, arts, and social science. We excluded students who majored in science or engineering; therefore, the participants were expected to have minimal background knowledge in science and engineering.
- All participants had normal or corrected-to-normal vision.

Apparatus

- Eye movements were recorded by an Eyelink 1000 with a sampling rate of 1000HZ. A chin rest was used to minimize head movement.
- Texts were displayed on the 24-inch LCD monitor. The screen resolution was set to 1920*1200 pixels. The distance between the monitor and participants was 60 cm.
- The reading material covered 46° (horizontal) × 30° (vertical) of visual angle on the screen.

Materials

- There were two reading materials about a mechanical system, one was the mechanical configurations, which consisted of text or a diagram (as Figure 1a and 1c); the other was a text describing kinematic information of the same system, describing the “outlet process” and “inlet process” of the flushing cistern, respectively.
- There were three groups: configuration, non-configuration (as Figure 1b), or diagram.

虹吸式馬桶的儲水槽由十個部件組成。把手鑲嵌在儲水槽側面上方的位置，把手在槽內的一端接著一根連接桿，連接桿的另一端有一個支點，連接著另一根向下的連接桿，它穿過上圓盤的小洞，並連接下圓盤；上圓盤是可活動的，下圓盤則與連接桿固定，兩個圓盤約略是疊合的狀態，都位於虹吸鐘內。上圓盤較小，下圓盤則大約與虹吸鐘內緣的面積相近。虹吸鐘是一個鐘形的物件，上方為一條彎曲的虹吸管，虹吸管向下彎，狀如拐杖，穿過儲水槽到外面的排水系統。而把手下方有一個入水管，入水管是穿入儲水槽的水平管子，開口處有一個塞子。槽內有一根浮臂勾著塞子，浮臂的另一端連接著浮球；在這根浮臂的中間有一個支點連接著另一根浮臂，扣住在入水管下方的側壁固定點。這是虹吸式馬桶的儲水槽內部結構。

Figure 1a. The first learning material: the editions of the text described the mechanical configurations (**the configuration group**).

虹吸式馬桶的儲水槽由十個部件組成。把手的材質是塑鋼，硬度高，可多次按壓，不易斷裂。入水管的材質是不鏽鋼，不易生鏽的原因是鋼的表面有一層保護膜，可以保護鋼材本身不受環境中空氣與水的氧化。浮臂的材質是鋁，重量輕且硬度高，與不鏽鋼材質的入水管一樣，表面都會形成一層薄膜，阻絕空氣，避免氧化。連接桿的材質是塑膠，特性是重量輕。浮球的材質也和連接桿一樣都是塑膠，浮球是一個空心球體，材質柔軟且比水輕。虹吸鐘與虹吸管的材質都是陶瓷，表面光滑且能抗髒污，容易清洗，也具有抗酸耐鹼的特性。上圓盤與下圓盤的材質都是橡皮，具有可與其他部件緊密貼合的性質。塞子的材質也和上圓盤、下圓盤一樣都是橡皮，具有高度密合性，可有效避免漏水。這是虹吸式馬桶的儲水槽內部部件。

Figure 1b. The first learning material: the editions of the text described the mechanical configurations (**the non-configuration group**).

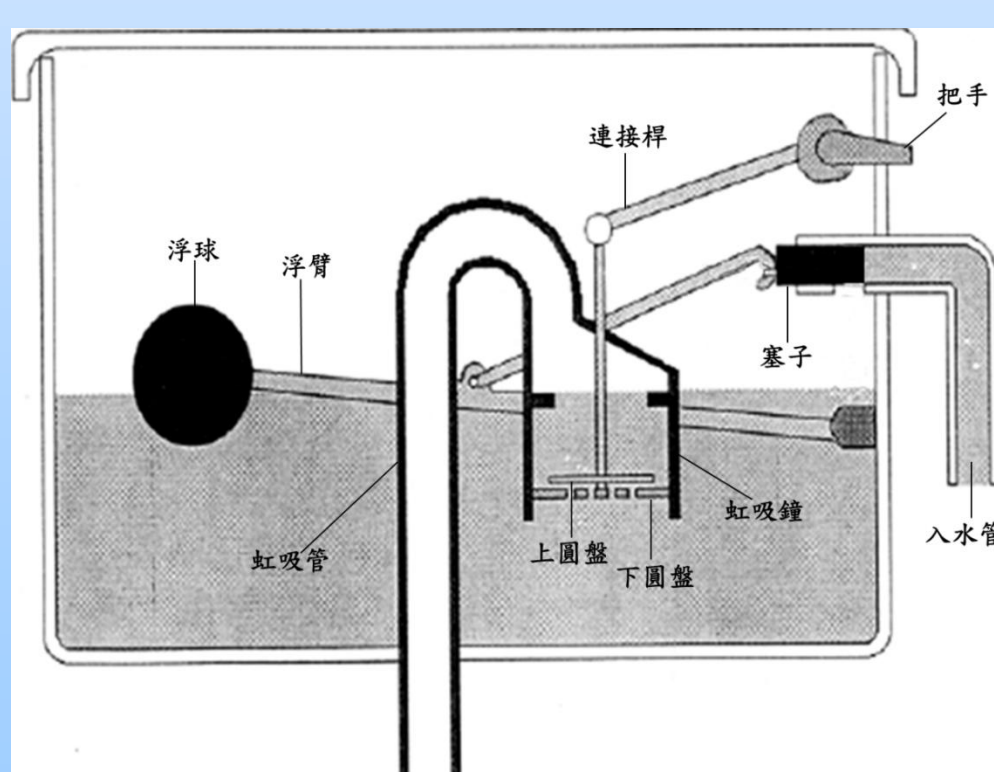

Figure 1c. The first learning material: the editions of the text described the mechanical configurations (**the diagram group**).

Procedure

- We employed a two-stage procedure.
- Firstly, participants read the mechanical configurations described by text or diagram or control condition, then they completed a yes/no test measured configurations between components, and be asked to draw a picture to express what they thought about the mechanical configuration they learned.
- Secondly, participants read a text describing kinematic information of the same system, and then modified the picture they drawn.
- 12-point calibration and validation of eye-movements were conducted before each of reading procedures.
- It took approximately 50–60 minutes for each participant to complete the experimental procedure.

Result

The result of the configuration tests

- Table 1 showed that the configuration group had higher configuration test scores than the non-configuration group; the configuration test scores regarding local connective relations were also higher for the configuration group than for the diagram group. However, on the global dimension of the same test, the diagram group performed better than the configuration group.
- The revised tests measured local connective relations between components were significantly better than the first test for the non-configuration group and for the diagram group.

Table 1. Accuracy of the configuration tests for three groups

Accuracy (%)	Configuration group		Non-configuration group		Diagram group	
	M	SD	M	SD	M	SD
Yes/no test						
First test	88	(17)	45	(13)	68	(10)
Revised test	95	(10)	72	(14)	89	(12)
Draw a picture						
Local connective relations						
First test	98	(5)	31	(19)	75	(17)
Revised test	98	(5)	74	(24)	88	(11)
Global similarity (1~5)						
First test	2.15	(0.88)	1.56	(0.62)	3.26	(0.73)
Revised test	2.20	(0.83)	2.11	(0.47)	3.37	(0.76)

The result of eye movements

- Table 2 showed the configuration group displayed shorter total fixation durations and second-pass reading time of the kinematic text than the other two groups did.

Table 2. Eye-movement measures for three groups while analyzed the text describing kinematic information.

Areas of Interest	Configuration group		Non-configuration group		Diagram group	
	M	SD	M	SD	M	SD
The whole text						
Total fixation duration (sec)	183.14	(76.51)	305.80	(155.94)	252.79	(107.17)
The sentences						
Total fixation duration (sec)						
Outlet-process sentences	85.90	(45.29)	163.33	(89.31)	119.63	(49.11)
Inlet-process sentences	34.10	(16.93)	57.89	(28.31)	42.05	(19.66)
First-pass fixation time (sec)						
Outlet-process sentences	30.50	(13.99)	39.33	(26.19)	36.53	(21.68)
Inlet-process sentences	14.25	(6.77)	19.72	(10.03)	13.95	(6.65)
Second-pass fixation time (sec)						
Outlet-process sentences	55.40	(44.45)	124.11	(90.45)	83.05	(47.92)
Inlet-process sentences	20.05	(17.34)	38.11	(24.94)	27.89	(18.67)

Conclusions

- We argue that readers were able to form a mental representation of the mechanical configuration described by written words.
- Advantages of the text and diagrams are describe local connective relations and global analogical relations, respectively, within the mechanical system.
- Kinematic information helps readers adjusted their inner representation of configurations of the flushing cistern.

Acknowledgment

This study is supported by the grant NSC101-2511-S-003-015 from the National Science Council in Taiwan